



OWNER'S MANUAL

EHVS-80CS Edge Horizontal/Vertical Sander



JET EQUIPMENT & TOOLS, INC.
A WMH Company
www.jettools.com

P.O. BOX 1349
Auburn, WA 98071-1349
e-mail jet@jettools.com

253-351-6000
Fax 253-939-8001
M-708448 2/02

This manual has been prepared for the owner and operators of a JET EHVS-80CS Sander. Its purpose, aside from machine operation, is to promote safety through the use of accepted correct operating and maintenance procedures. Completely read the safety and maintenance instructions before operating or servicing the machine. To obtain maximum life and efficiency from your sander, and to aid in using the machine safely, read this manual thoroughly and follow instructions carefully.

Warranty & Service

The JET Group warrants every product it sells. If one of our tools needs service or repair, one of our Authorized Repair Stations located throughout the United States can give you quick service.

In most cases, any one of these JET Group Repair Stations can authorize warranty repair, assist you in obtaining parts, or perform routine maintenance and major repair on your JET, Performax or Powermatic tools.

For the name of an Authorized Repair Station in your area, please call 1-800-274-6848.

More Information

Remember, the JET Group is consistently adding new products to the line. For complete, up-to-date product information, check with your local JET Group distributor.

JET Group Warranty

The JET Group (including Performax and Powermatic brands) makes every effort to assure that its products meet high quality and durability standards and warrants to the original retail consumer/purchaser of our products that each product be free from defects in materials and workmanship as follow: 1 YEAR LIMITED WARRANTY ON ALL PRODUCTS UNLESS SPECIFIED OTHERWISE. This Warranty does not apply to defects due directly or indirectly to misuse, abuse, negligence or accidents, normal wear-and-tear, repair or alterations outside our facilities, or to a lack of maintenance.

THE JET GROUP LIMITS ALL IMPLIED WARRANTIES TO THE PERIOD SPECIFIED ABOVE, FROM THE DATE THE PRODUCT WAS PURCHASED AT RETAIL. EXCEPT AS STATED HEREIN, ANY IMPLIED WARRANTIES OR MERCHANTABILITY AND FITNESS ARE EXCLUDED. SOME STATES DO NOT ALLOW LIMITATIONS ON HOW LONG THE IMPLIED WARRANTY LASTS, SO THE ABOVE LIMITATION MAY NOT APPLY TO YOU. THE JET GROUP SHALL IN NO EVENT BE LIABLE FOR DEATH, INJURIES TO PERSONS OR PROPERTY, OR FOR INCIDENTAL, CONTINGENT, SPECIAL, OR CONSEQUENTIAL DAMAGES ARISING FROM THE USE OF OUR PRODUCTS. SOME STATES DO NOT ALLOW THE EXCLUSION OR LIMITATION OF INCIDENTAL OR CONSEQUENTIAL DAMAGES, SO THE ABOVE LIMITATION OR EXCLUSION MAY NOT APPLY TO YOU.

To take advantage of this warranty, the product or part must be returned for examination, postage prepaid, to an Authorized Repair Station designated by our office. Proof of purchase date and an explanation of the complaint must accompany the merchandise. If our inspection discloses a defect, we will either repair or replace the product, or refund the purchase price if we cannot readily and quickly provide a repair or replacement, if you are willing to accept a refund. We will return repaired product or replacement at JET'S expense, but if it is determined there is no defect, or that the defect resulted from causes not within the scope of JET'S warranty, then the user must bear the cost of storing and returning the product. This warranty gives you specific legal rights; you may also have other rights which vary from state to state.

The JET Group sells through distributors only. Members of the JET Group reserve the right to effect at any time, without prior notice, those alterations to parts, fittings, and accessory equipment which they may deem necessary for any reason whatsoever.

WARNING

1. **Read and understand the entire instruction manual before attempting assembly or operation.**
2. **This sander is designed and intended for use by properly trained and experienced personnel only. If you are not familiar with the proper and safe operation of a sander, do not use until proper training and knowledge have been obtained.**
3. Always wear approved safety glasses/face shields while using this machine.
4. Make certain the machine is properly grounded.
5. Before operating the machine, remove tie, rings, watches, other jewelry, and roll up sleeves above the elbows. Remove all loose clothing and confine long hair. Do **not** wear gloves.
6. Keep the floor around the machine clean and free of scrap material, oil and grease.
7. Keep machine guards in place at all times when the machine is in use. If removed for maintenance purposes, use extreme caution and replace the guards immediately.
8. Do **not** over reach. Maintain a balanced stance at all times so that you do not fall or lean against blades or other moving parts.
9. Make all machine adjustments or maintenance with the machine unplugged from the power source.
10. Use the right tool. Don't force a tool or attachment to do a job that it was not designed for.
11. Replace warning labels if they become obscured or removed.
12. Make certain the switch is in the **OFF** position before connecting the machine to the power supply.
13. Give your work undivided attention. Looking around, carrying on a conversation, and "horse-play" are careless acts that can result in serious injury.
14. Keep visitors a safe distance from the work area.
15. Use recommended accessories; improper accessories may be hazardous.
16. Read and understand warnings posted on the machine.
17. Failure to comply with all of these warnings may cause serious injury.
18. Some dust created by power sanding, sawing, grinding, drilling and other construction activities contains chemicals known to cause cancer, birth defects or other reproductive harm. Some examples of these chemicals are:
 - Lead from lead based paint
 - crystalline silica from bricks and cement and other masonry products, and
 - arsenic and chromium from chemically-treated lumber.
19. Your risk from those exposures varies, depending on how often you do this type of work. To reduce your exposure to these chemicals: work in a well ventilated area, and work with approved safety equipment, such as those dust masks that are specifically designed to filter out microscopic particles
20. Do not operate tool while under the influence of drugs, alcohol or any medication.

Grounding Instructions

Caution: This tool must be grounded while in use to protect the operator from electric shock.

In the event of a malfunction or breakdown, grounding provides a path of least resistance for electric current to reduce the risk of electric shock. This tool is equipped with an electric cord having an equipment-grounding conductor and a grounding plug. The plug must be plugged into a matching outlet that is properly installed and grounded in accordance with all local codes and ordinances.

Do not modify the plug provided. If it will not fit the outlet, have the proper outlet installed by a qualified electrician.

Improper connection of the equipment-grounding conductor can result in a risk of electric shock. The conductor, with insulation having an outer surface that is green with or without yellow stripes, is the equipment-grounding conductor. If repair or replacement of the electric cord or plug is necessary, do not connect the equipment-grounding conductor to a live terminal.

Check with a qualified electrician or service personnel if the grounding instructions are not completely understood, or if in doubt as to whether the tool is properly grounded. Use only three wire extension cords that have three-prong grounding plugs and three-pole receptacles that accept the tool's plug.

Repair or replace a damaged or worn cord immediately.

115 Volt Operation

As received from the factory, your sander is ready to run at 115 volt operation. This sander, when wired for 115 volt, is intended for use on a circuit that has an outlet and a plug that looks like the one illustrated in (A). A temporary adapter, which looks like the adapter as illustrated in (B), may be used to connect this plug to a two-pole receptacle, as shown in (B) if a properly grounded outlet is not available. The temporary adapter should only be used until a properly grounded outlet can be installed by a qualified electrician. **This adapter is not applicable in Canada.** The green colored rigid ear, lug, or tab, extending from the adapter, must be connected to a permanent ground such as a properly grounded outlet box, as shown in (B).

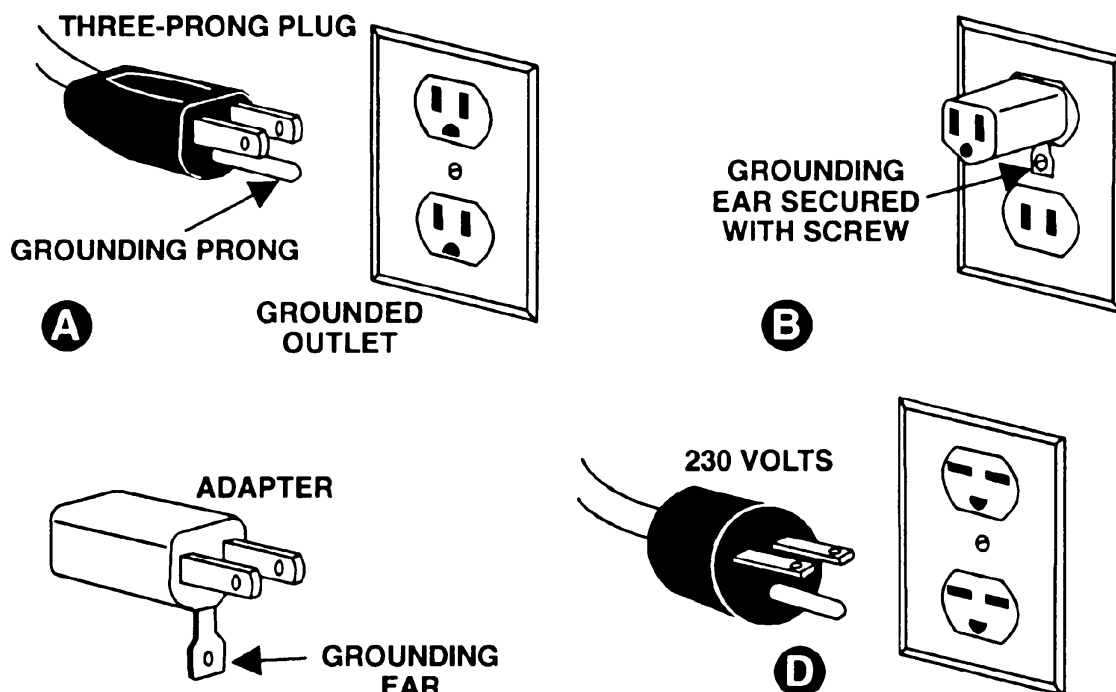

230 Volt Operation

WARNING!

**All electrical connections must be done by a qualified electrician!
Failure to comply may result in serious injury!**

If 230V operation is desired, the following instructions must be followed:

1. **Disconnect the machine from the power source.**
2. This sander is supplied with four motor leads that are connected for 115V operation, as shown in Figure A. Reconnect these four motor leads for 230V operation, as shown in Figure B.
3. The 115V attachment plug (A), supplied with the sander, must be replaced with a UL/CSA listed plug suitable for 230V operation (D). Contact your local Authorized JET Service Center or qualified electrician for proper procedures to install the plug. The sander must comply with all local and national codes after the 230 volt plug is installed.
4. The sander with a 230 volt plug should only be connected to an outlet having the same configuration (D). No adapter is available or should be used with the 230 volt plug.

Important: In all cases (115 or 230 volts), make certain the receptacle in question is properly grounded. If you are not sure, have a registered electrician check the receptacle.

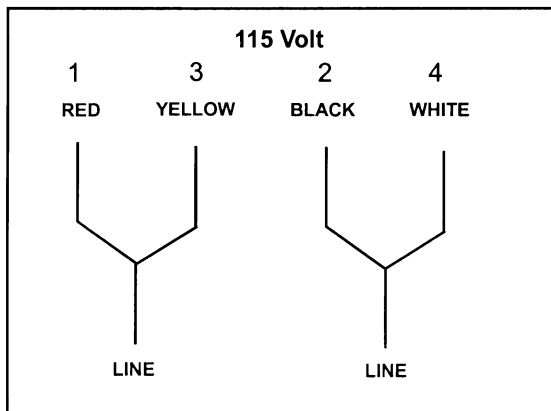

FIGURE A

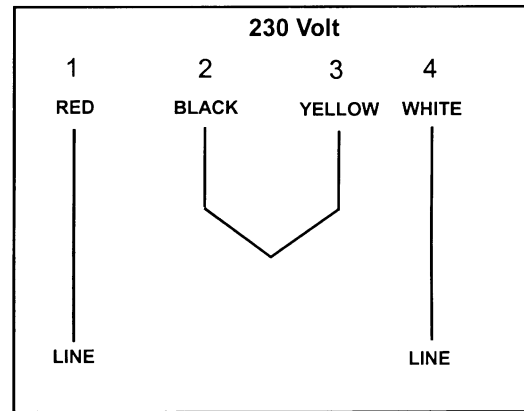
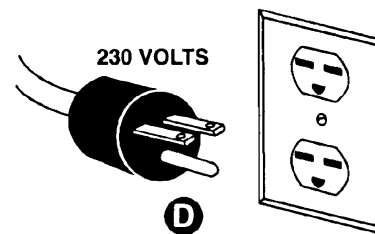
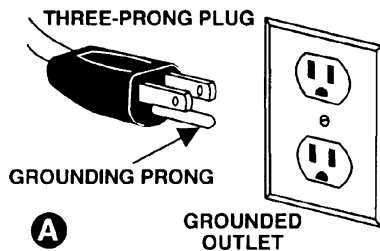

FIGURE B



Specifications:

EHVS-80CS

Stock Number.....	708448
Fence	4"H x 24"L
Abrasive Belt Size	6"W x 89"L
Dust Chute Diameter	4"
Extension Table Size.....	9-7/8 x 11-7/8
Table Size	32"L x 7"W
Table Tilt	90°
Motor (UL Listed).....	1-1/2 HP, 1 Ph
.....	115/230V, prewired 115
Belt Speed (SPFM).....	3,900
Overall Dimensions	51"L x 26.5"W x 20"H
Net Weight (approx.)	256 lbs.
Shipping Weight (approx.)	262 lbs.

Table of Contents

Warranty	2
Warning.....	3
Grounding Instructions.....	4
115V Operation	4
230V Operation	5
Specifications	6
Table of Contents	6
Contents of the Shipping Container	7
Tools Needed for Assembly	7
Assembly.....	8-9
Horizontal Sanding	10
Vertical Sanding	10
Contour Sanding.....	10
Sanding Platen Angle Adjustment.....	10
Platen Lock Tension Adjustment.....	11
Changing the Sanding Belt	11
Belt Tracking Adjustment.....	11-12
Motor Mount Tracking Adjustment	12
Table Adjustment.....	13
Troubleshooting.....	13
Parts Breakdowns and Parts Lists.....	14-18
Wiring Diagram	19

The specifications in this manual are given as general information and are not binding. JET Equipment & Tools reserves the right to effect, at any time and without prior notice, changes or alterations to parts, fittings, and accessory equipment deemed necessary for any reason whatsoever.

Contents of the Shipping Container

1. Stand (front)
1. Stand (rear)
2. Stand (sides)
1. Extension Table Assembly
1. Extension Cover
1. Owner's Manual
1. Warranty Card
1. Sanding Unit with Motor
1. Back Stop
1. Handle
1. Driver Wrench
1. Miter Gauge Assembly
1. Sanding Belt
1. Adjusting Wrench
1. Assembly Hardware:
 - Cabinet*
 1. Lock Knob (20mm Length)
 2. Lock Knob (12mm Length)
 1. Lock Knob (35mm Length)
 4. Cabinet Pads
 4. 5/16" x 5/8" Screws
 22. 5/16" Flat Washers
 12. 5/16" Hex Nuts
 8. 5/16" x 5/8" Hex Cap Bolts
 2. 5/16" x 1-1/4" Hex Cap Bolts
 4. Larger O/D 5/16" Flat Washers
 10. 5/16" Lock Washers
 - Extension Table*
 5. 1/4" x 5/8" Hex Cap Bolts
 5. 1/4" Flat Washers
 5. 1/4" Lock Washers
 1. Bracket
 1. 3mm Hex Wrench
 - Dust Chute*
 3. Pan Head Screws



Tools Needed for Assembly

- 2) 12mm Wrench or sockets
- 1) 10mm Wrench or sockets
- 1) Flat Head Screw Driver
- 1) Cross Point Screw Driver

Assembly

1. Remove all contents from the shipping container.
2. Clean all rust protected surfaces with a mild solvent. Do not use paint or lacquer thinner, gasoline, or mineral spirits; these will damage painted surfaces.
3. Attach the *four* rubber pads (A, Fig. 1) to the bottoms of the side panels with *four* 5/16" x 5/8" Screws, *four* 5/16" flat washers and *four* 5/16" hex nuts (B, Fig. 1). The hardware can be found in the bag with the rubber pads.
4. Attach the side panels (C, Fig. 1) to the front panel (D, Fig. 1) with *four* 5/16" x 5/8" hex cap bolts, *eight* 5/16" flat washers, *four* 5/16" lock washers, and *four* 5/16" hex nuts (E, Fig. 1). Hand tighten the hardware at this point.
Note: Assemble the stand up side down to make sure that the tops of the panels are flush.
5. Mount the shelf (F, Fig. 1) to the inside of the stand with *two* M5x10 pan head screws and *two* M5 lock washers (G, Fig. 1).
6. Finish stand assembly by attaching rear panel to side panels with *four* 5/16" x 5/8" hex cap bolts, *eight* 5/16" flat washers, *four* 5/16" lock washers, and *four* 5/16" hex nuts.
7. Make sure stand is sitting evenly on a level surface before tightening hardware.



WARNING

Main unit is heavy! Use great care and adequate resources when lifting the unit up onto the stand!
Failure to comply may cause serious injury and/or damage to the sander and/or property!

8. With the aid of another person, carefully lift the main unit out of the shipping box, and up onto the stand. Line up threaded holes in sander base with holes in stand.
9. Through the door in the cabinet attach main unit to stand with *two* 5/16" x 1-1/4" hex cap bolts, *two* 5/16" lock washers and *two* 5/16" flat washers.

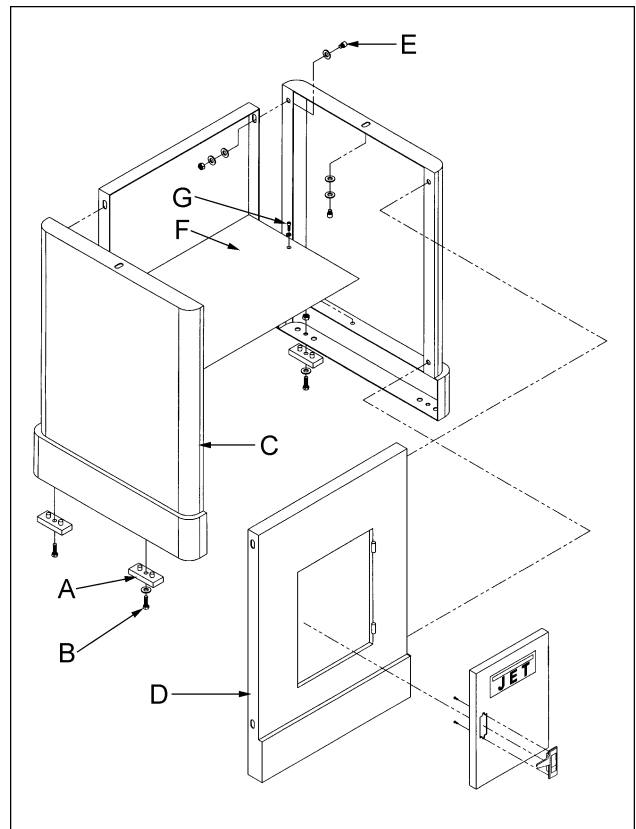

Fig. 1



Fig. 2

10. Sanding platen is presently in a horizontal position. Pull lock handle forward (A, Fig. 3) to unlock platen assembly, tilt sanding platen to the vertical position, and push lock handle to lock platen assembly in place.

Note: do not turn lock handle. Turning or rotating the lock handle will change the tension of the locking assembly. This may cause the locking assembly not to work; making it necessary for adjustment before using the machine.

11. Remove the belt guards by unscrewing *two* lock knobs (A, Fig. 4). Take out sanding belt and fence from behind the belt guard.
12. Place handle (B, Fig. 4) on belt tensioning shaft. Take tension off the mechanism by moving the handle to the left.
13. Make sure that direction arrow on belt matches direction indicator on the belt cover.
14. Place belt on both rollers so that the edge of the belt is even with the edge of the rollers.

15. Tension the belt by moving the tension handle lever (B, Fig. 4) to the right. Rotate the belt by hand in the direction indicated by the arrow on the belt guard. If belt tracking needs adjustment, see "Belt Tracking Adjustment" pages 11-12.

16. Attach the extension bracket (A, Fig. 5) using *three* hex cap bolts, *three* lock washers and *three* flat washers (B, Fig. 5). The hardware can be found in the bag with the 3mm Hex Wrench.

17. Fasten the extension table (C, Fig. 5) to the support rod (D, Fig. 5) by tightening the hex cap screw (E, Fig. 5) against the flat on the support rod. Tighten the jam nut.

18. Raise the table to a good height and tighten *two* set screws on the bracket.

19. Mount the small bracket between the backside of the extension bracket and the sander using *two* hex cap bolts, *two* lock washers and *two* flat washers.

20. Connect the sander to the power source, turn on the power to the machine just enough to start the belt rotating and then turn off. Do this several times and observe belt tracking. The belt should not wander up or down. It should be centered between the two belt rollers. If adjust is necessary refer to "Belt Tracking Adjustment" pages 11-12.

21. Reinstall the guards and secure in place with lock knobs.

22. Attach the extension cover (D, Fig. 6) with *three* pan head screws and one lock knob.



Fig. 3

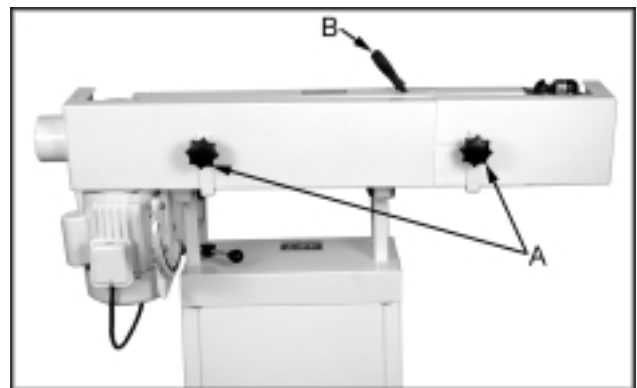

Fig. 4

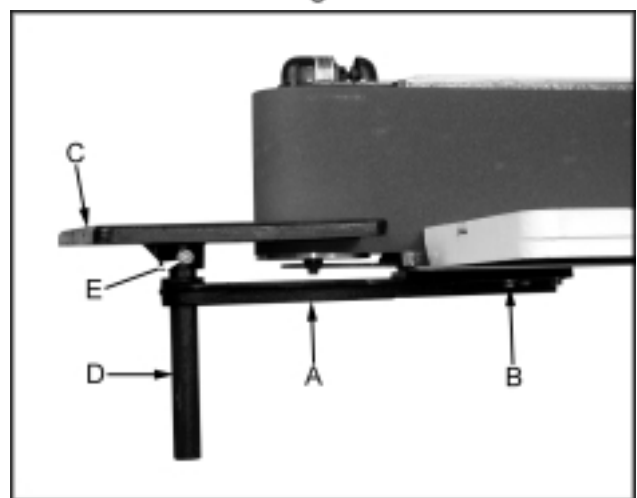

Fig. 5

⚠ WARNING

Removing the belt guard exposes more of the sanding belt! Replace the belt guards immediately after completing any sanding that requires it's removal!

Failure to comply may cause serious injury!

Horizontal Sanding

With the sanding platen locked in the horizontal position, the removable fence (A, Fig. 6) may be used. The fence can be secured in place by screwing two lock knobs (B, Fig. 6) into the guide blocks found in the miter slot. Adjust the table so the fence is at a good height, see "Table Adjustment" page 13..

The backstop (C, Fig. 6) can also be used by removing the extension pin cover (D, Fig. 6) and placing the backstop pin in the positioning hole and securing in place with the lock knob. The extension cover can be reinstated.

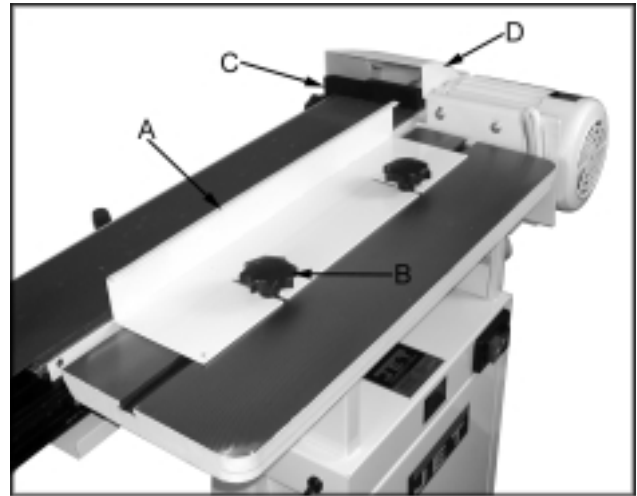

Fig. 6

Vertical Sanding

With the sanding platen locked in the vertical position, the backstop (A, Fig. 7) and/or the miter gauge (B, Fig. 7) may be used.

If you need to do precise 90° work use a square between the table and sanding platen. Adjust for square.

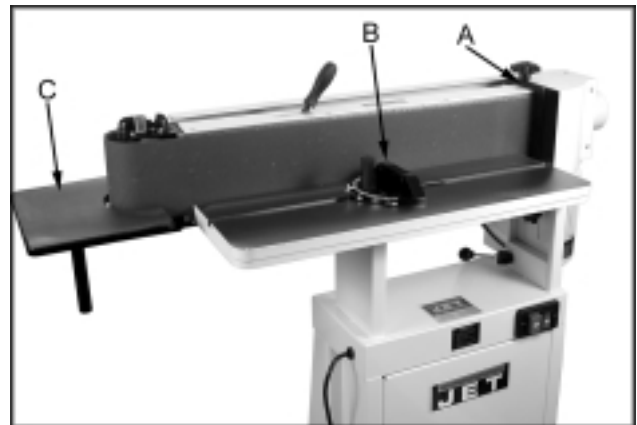

Fig. 7

Contour Sanding

The use of extension table (C, Fig. 7) is optional according to the particular function of the sanding operation. The end guard should always be in place if the extension table is not being used.

Sanding Platen Angle Adjustment

1. **Disconnect the machine from the power source.**
2. Pull handle (A, Fig. 8) forward to release tension.
3. Move sanding platen to desired position and hold while locking handle.
4. Use a combination square between the table and sanding platen to get precise angles.



Fig. 8

Platen Lock Tension Adjustment

1. **Disconnect the machine from the power source.**
2. Loosen lock handle by pulling forward (A, Fig. 9) and move motor and sanding table toward the horizontal position. Do not lock.
3. Tension eccentric block by tightening the nyloc nut (B, Fig. 9) with a 14mm wrench. Turn the nut in $\frac{1}{4}$ turn increments and test locking handle for proper tension. Locking handle is properly tensioned when it requires positive force to move the eccentric block (attached to the locking handle) from one side to the other. The platen and motor assembly must stay in a locked position without sliding once the handle has been moved to the locked position. Re-adjust as necessary.

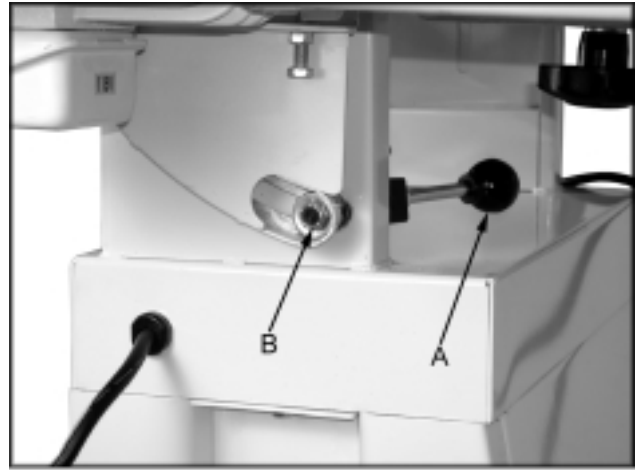

Fig. 9

Changing the Sanding Belt

1. **Disconnect the machine from the power source.**
2. Lock sanding platen in the vertical position.
3. Release tension on the belt by pushing handle (A, Fig. 10) to the left (as the operator faces the machine).
4. Remove belt guards.
5. Carefully remove old belt. Observe direction arrow on inside of sanding belt. Make sure that direction arrow on belt matches direction indicator on the belt cover. Install new belt over both rollers and line up edge of belt with edge of rollers.
6. Tension belt by pushing handle to the right.
7. Reinstall the belt guards

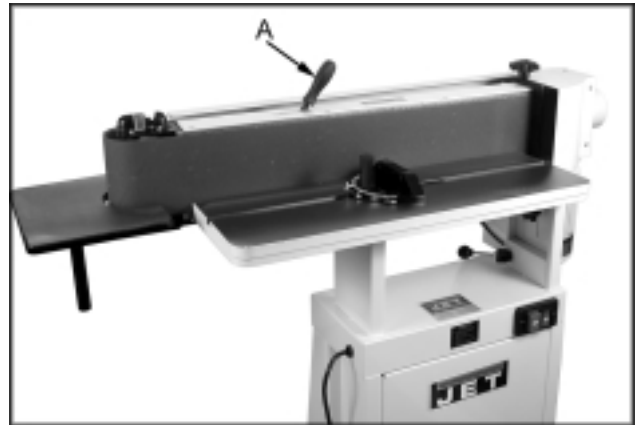

Fig. 10

Note: Belts stretch with wear. You may have to adjust tracking with a new belt.

Belt Tracking Adjustment

1. **Disconnect the machine from the power source.**
2. Push the belt by hand in the direction indicated on the belt cover. Observe the belt position on the rollers. Edge of belt should remain even with the edge of the rollers.

3. Insert the driver with the round shaft, supplied with the machine into the micro adjusting nut (A, Fig. 11) and turn away from you to loosen.
4. Turn the micro adjusting screw (B, Fig. 11) in $\frac{1}{4}$ turn increments until the belt tracks evenly on the rollers when rotated by hand.
5. Tighten the micro adjusting nut (A, Fig. 11).
6. Connect the machine to power.
7. Turn on the power to the machine just enough to start the belt rotating and then turn off. Do this several times and observe belt tracking. Adjust as necessary. If the tracking cannot be corrected goto the next section "Motor Mount Tracking Adjustment".

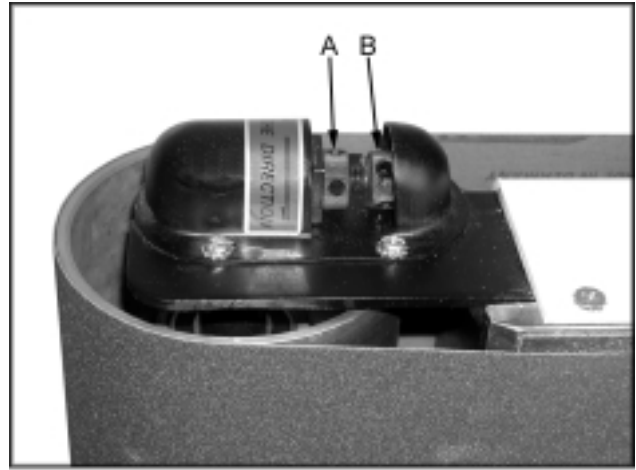

Fig. 11

Motor Mount Tracking Adjustment

The EHVS-80CS comes with tracking adjustment bolts (A, Fig. 12) on the motor plate. These are set at the factory and should not require any further adjustment. If, however, you are not able to track the belt using the belt tracking adjustment assembly on the sanding platen, the motor mount bolts will have to be adjusted:

1. **Disconnect the machine from the power source.**
2. Slightly loosen the four motor mount nuts (B, Fig. 12) just enough so the tracking bolts can make an adjustment.
3. Loosen both locking hex nuts.
4. Turn one bolt (A, Fig. 12) a $\frac{1}{4}$ turn and rotate the sanding belt by hand to observe which direction the belt is tracking. If it is traveling in the direction needed to correctly track the belt, tighten both locking nuts and fine tune the tracking with the belt tracking assembly on the platen.
5. If the belt starts to travel in the wrong direction, back off a quarter turn and tighten the other bolt a quarter turn. This should start the belt in the proper direction.

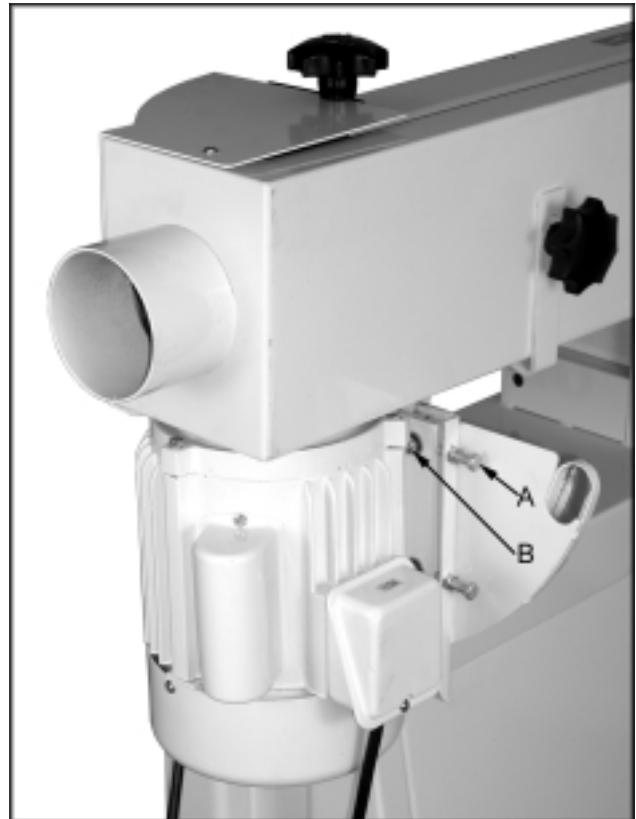

Fig. 12

Note: Use the motor mount bolts as a "major" tracking adjustment. Use the belt tracking assembly on the sanding plates as a "fine" tracking adjustment.

Table Adjustment

⚠ WARNING

**Do not position table below sanding belt!
Keep an overlap of at least 1/16" between
table and sanding belt to avoid material
and/or fingers getting caught!
Failure to comply may cause serious injury!**

1. Loosen two lock knobs (A, Fig. 13).
2. Raise or lower work table to desired level.
3. Tighten two lock knobs.

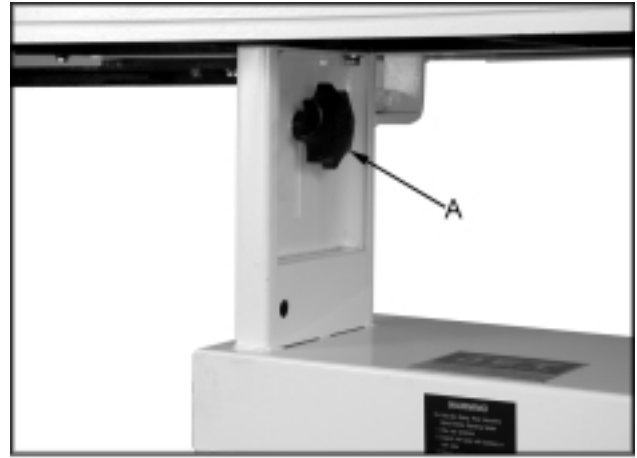
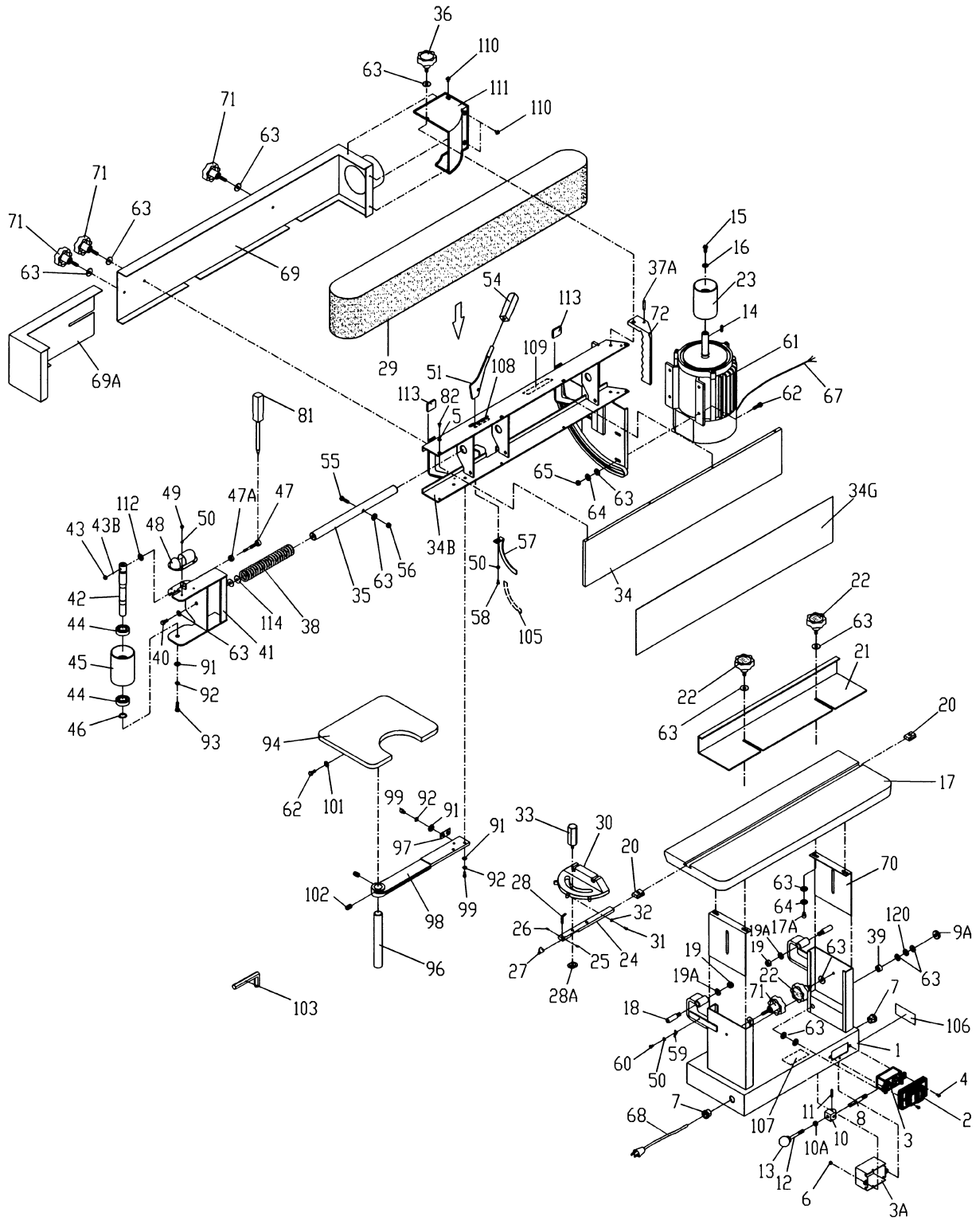

Fig. 13

Troubleshooting

Trouble	Possible Cause	Solution
Sander will not start	<ol style="list-style-type: none"> 1. Sander unplugged from wall or motor 2. Fuse blown or circuit breaker tripped 3. Cord damaged 	<ol style="list-style-type: none"> 1. Check all plug connections 2. Replace fuse or reset circuit breaker 3. Replace cord
Sanding belt does not come up to speed	<ol style="list-style-type: none"> 1. Extension cord too light or too long 2. Motor not wired for proper voltage 3. Low current 	<ol style="list-style-type: none"> 1. Replace with adequate size and length cord 2. Refer to motor junction cover for proper wiring 3. Contact a qualified electrician
Machine vibrates excessively	<ol style="list-style-type: none"> 1. Stand on uneven floor 2. Motor mounts are loose 3. Tension spring is worn or broken 	<ol style="list-style-type: none"> 1. Adjust stand so that it rests evenly on the floor 2. Tighten motor mount bolts 3. Replace spring
Abrasive belt keeps tearing	<ol style="list-style-type: none"> 1. Belt is running in the wrong direction 	<ol style="list-style-type: none"> 1. Arrow on the sanding belt and machine should be pointing in the same direction.
Sanded edge not square	<ol style="list-style-type: none"> 1. Table not square to sanding platen 	<ol style="list-style-type: none"> 1. Use a square to adjust table to sanding platen
Sanding marks on wood	<ol style="list-style-type: none"> 1. Work held still 2. Wrong grit sanding belt 3. Feed pressure too great 4. Sanding against the grain 	<ol style="list-style-type: none"> 1. Keep workpiece moving 2. Use coarser grit for stock removal and fine grit for finish sanding. 3. Never force work into sanding platen 4. Sand with the grain

Table and Motor Assembly



Parts List For The EHVS-80CS Sander

Table and Motor Assembly

Index No.	Part No.	Description	Size	Qty.
1	EHVS80CS-01	Base		1
2	994532	Switch (serial #: 9031435 and lower)		1
	EHVS80-02N	Push Button Switch (serial #: 9031436 and higher)		1
3	EHVS80-03-1	Switch Panel (serial #: 9031435 and lower)		1
	EHVS80-03N	Switch Panel (serial #: 9031436 and higher)		1
3A	EHVS80-02B	Switch Box		1
4	EHVS80-04	Pan Head Screw	3/16"x1-1/2"	3
5	EHVS80-05A	External Tooth Lock Washer	3/16"	3
6	EHVS80-06	Nut	3/16"	2
7	EHVS80-07	Nylon Clamp		2
8	EHVS80-08	Work Table Bracket		1
9A	EHVS80-09A	Nut (serial#: 1023018 and higher)	3/8"	1
	EHVS80-09	Locking Collar (serial#: 1013017 and lower)		1
10A	TS-0561031	Hex Nut	3/8"	1
10	EHVS80-10	Locking Block		1
11	EHVS80-11	Spring Pin	M4	1
12	EHVS80-12	Lock Handle		1
13	10102023A	Knob		1
	EHVS80-12A	Lock Handle Assembly (#12,13)		1
14	S0430525	Key	5x5x25	1
15	EHVS80-15	Hex Cap Bolt	1/4"x3/4"	1
16	TS-0561011	Washer	1/4"	1
17	EHVS80-17	Table		1
17A	EHVS80-17A	Hex Cap Bolt	5/16"x5/8"	4
18	EHVS80-18	Screw	M10	2
19	TS-1540073	Hex Nut	M10	2
19A	TS-0720091	Lock Washer	3/8"	2
20	EHVS80-20	Guide Block		2
21	EHVS80-21	Fence		1
22	EHVS80-22A	JETKnob (serial#: 1023018 and higher)	M8x12mm	3
	EHVS80-22B	Knob (serial#: 1013017 and lower)	M8x12mm	3
23	EHVS80-23	Motor Roller		1
24	EHVS80-24	Guide Bar		1
25	S0310306	Pin	M3	1
26	EHVS80-26	Set Screw	1/4"x1/4"	1
27	EHVS80-27	Location Plate		1
28	EHVS80-28	Pointer		1
28A	EHVS80-28A	Locating Block		1
29	see page 17	Sanding Belt	6"x89"	1
30	10104046	Miter Gauge Body		1
	EHVS80-MG	Miter Gauge Assembly		1
31	S0030108	Round Head Screw	5/32"x5/8"	3
32	EHVS80-32	Nut	5/32"	3
33	EHVS80-33	Knob		1
34	20101048	Platen		1
34G	EHVS80-34G	Graphite		1
34B	EHVS80-34B	Side Plate		1
	TS-0051061	Hex Cap Bolt (motor plate – not shown)	5/16"x1-1/4"	2
	TS-0561021	Hex Nut (motor plate – not shown)	5/16"	2
35	EHVS80-35	Tension Bar		1
36	EHVS80-36A	JET Knob	M8x35mm	1

Index No.	Part No.	Description	Size	Qty.
37A	EHVS80-37A	Pin	M6x40mm	1
38	EHVS80-38	Spring		1
39	EHVS80-39A	Spacer		1
40	EHVS80-40	Hex Cap Bolt	5/16"x5/16"	1
41	EHVS80-41	Roller Arm		1
42	EHVS80-42	Shaft		1
43	EHVS80-43	Nut	1/4"	1
43B	TS-0267051	Set Screw		1
44	BB-6004ZZ	Ball Bearing	6004ZZ	2
45	EHVS80-45	Driven Roller		1
46	EHVS80-46	Spring Ring	STW-19	1
47	EHVS80-47	Mico-Adjusting Screw		1
47A	EHVS80-47A	Mico-Adjusting Nut		1
48	EHVS80-48	Protective Cover		1
49	S0030304	Round Head Screw	3/16"x3/8"	4
50	EHVS80-50	Star Washer	3/16"	15
51	EHVS80-51	Belt Tensioning Arm		1
54	EHVS80-54	Handle		1
55	TS-0051081	Hex Cap Bolt	5/16"X1-3/4"	1
56	TS-0561021	Hex Nut	5/16"	1
57	EHVS80-57	Tilt Scale		1
58	EHVS80-58	Hex Socket Screw	3/16"x3/8"	1
59	EHVS80-59	Pointer		1
60	EHVS80-60	Screw	3/16"x1/4"	1
61	EHVS80-61	Motor		1
62	TS-0051061	Hex Cap Bolt	5/16"x1-1/4"	2
63	TS-0680031	Washer	5/16"	26
64	TS-0720081	Lock Washer	5/16"	8
65	TS-0561021	Hex Nut	5/16"	6
67	EHVS80-67	Motor Cord		1
68	EHVS80-68	Power Cord		1
69	EHVS80-69	Belt Cover		1
69A	EHVS80-69A	Belt Cover (smaller)		1
70	EHVS80-70A	Up-Down Plate		2
71	EHVS80-71A	JET Knob	M8x20mm	4
72	EHVS80-72	Backstop		1
81	EHVS80-81	Driver Wrench		1
82	EHVS80-82	Flat Head Screw	3/16"x1/2"	8
91	TS-0680021	Flat Washer	1/4"	6
92	TS-0720071	Lock Washer	1/4"	6
93	EHVS80-93	Screw	M6x16mm	1
94	EHVS80-94	Extension Table		1
96	EHVS80-96	Supporting Rod		1
97	EHVS80-97	Mounting Bracket		1
98	EHVS80-98A	Bracket (serial#: 1023018 and higher)		1
	EHVS80-98	Bracket (serial#: 1013017 and lower)		1
99	TS-0050031	Hex Cap Bolt	1/4"x3/4"	5
103	EHVS80-103	Hex Wrench	3mm	1
102	TS-0267041	Set Screw	1/4"x3/8"	2
105	EHVS80-57A	Scale Label		1
106	EHVS80CS-106	I.D Label		1
107	EHVS80-107	Warning Label		1
108	EHVS80-108	Label		1

Index No.	Part No.	Description	Size	Qty.
109	EHVS80-109	Label		1
110	EHVS80-110	Pan Hand Screw	3/16"x3/8"	3
111	EHVS80-111	Extension Cover		1
112	EHVS80-112	Washer	1/4"	1
113	EHVS80CS-113	Protecting Rubber		2
114	TS-0680031	Washer	5/6"x23Dx2t	2
120	EHVS80CS-120	Fiber Washer	5/16"	1
	EHVS80-AT	Adjusting Tool (not show)		1
	EHVS80-HK	Hardware Kit (not show)		1
	EHVS80-MG	Miter Gauge Assembly Complete		1

Sanding Belts

40 Grit Open Coat	57422810
60 Grit Open Coat	57422910
80 Grit Open Coat	57423010
100 Grit Open Coat	57423110
120 Grit Open Coat	57423210
150 Grit Open Coat	57423310
180 Grit Open Coat	57423410
40 Grit Closed Coat	57618210
60 Grit Closed Coat	57618410
80 Grit Closed Coat	57618510
100 Grit Closed Coat	57618610
120 Grit Closed Coat	57618710
150 Grit Closed Coat	57512410
180 Grit Closed Coat	57512510

Stand Assembly

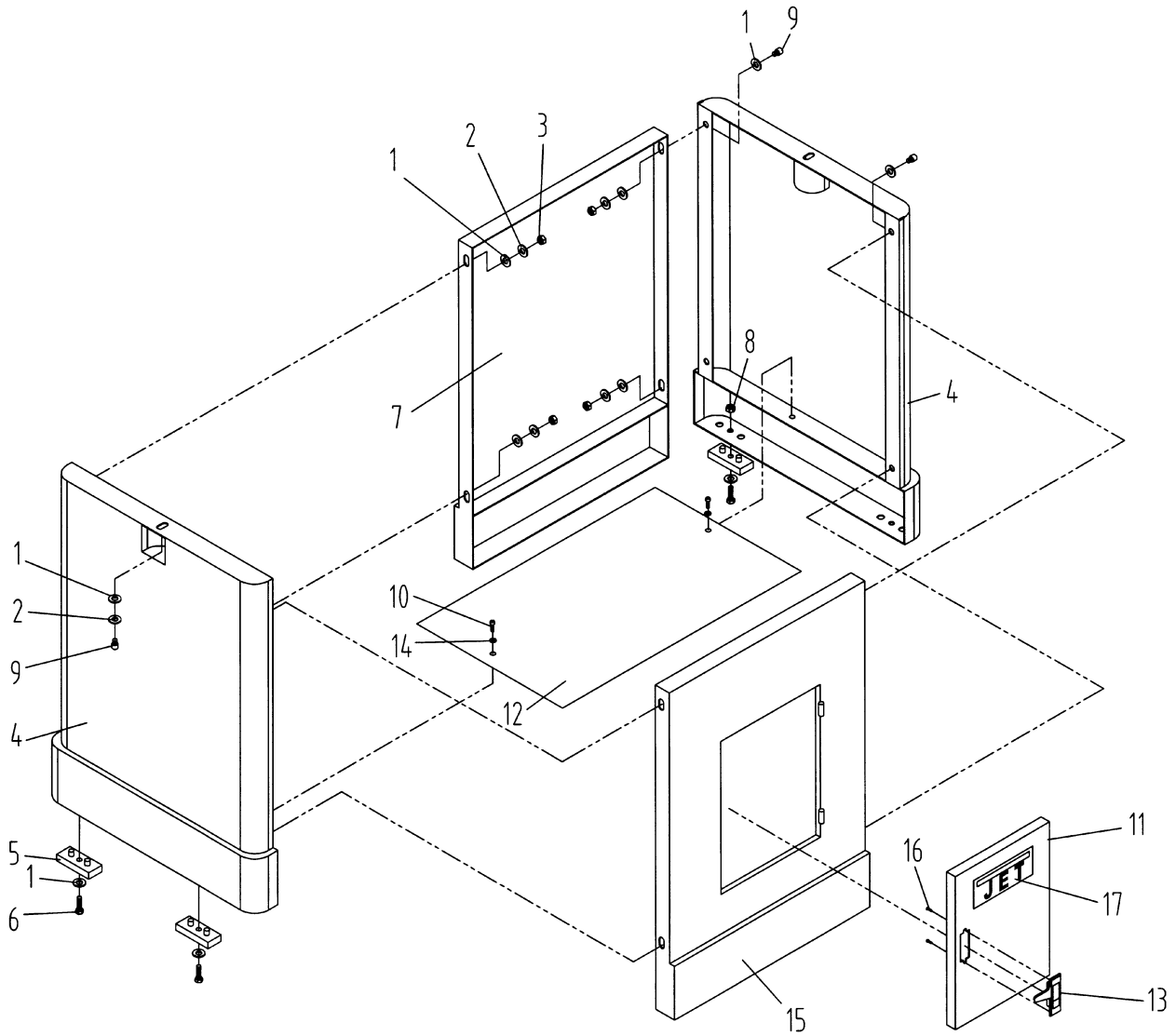

Index No.	Part No.	Description	Size	Qty.
1	TS-0680031	Flat Washer	5/16"	22
2	TS-0720081	Lock Washer	5/16"	10
3	TS-0561021	Hex Nut	5/16"	8
4	EHVS80CS-S04	Side Panel		2
5	EHVS80CS-S05	Pad		4
6	EHVS80CS-S06	Screw	5/16"x5/8"	4
7	EHVS80CS-S07	Rear Panel		1
8	TS-0561021	Hex Nut	5/16"	4
9	TS-0081031	Hex Cap Bolt	5/16"-3/4"	10
10	EHVS80CS-S10	Pan Head Screw	M5x10	2
11	EHVS80CS-S11	Door		1
12	EHVS80CS-S12	Shelf		1
13	EHVS80CS-S13	Latch Assembly		1
14	TS-1551031	Lock Washer	M5	2
15	EHVS80CS-S15	Front Panel (w/door)		1
16	EHVS80CS-S16	Pan Head Screw		2
17	EHVS80CS-S17	JET Label		1

EHVS-80CS Wiring Diagram - 115V

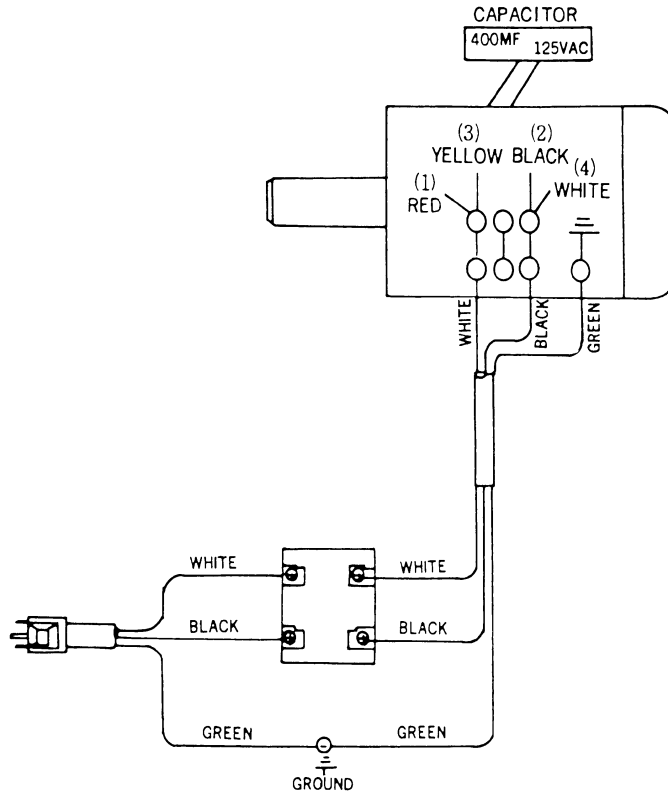

EHVS-80CS Wiring Diagram - 230V

